



Depend on Our Universal Axle Tool for Quick, Accurate Installations

Recognizing that most seal failures can be traced to improper installation, STEMCO has designed its Universal Axle Tool to make the procedure simpler, quicker and more consistent. Proper installation also reduces the possibility of more costly spindle damage.

Single Body with Interchangeable Heads

The STEMCO Universal Tool saves space and is easy to use.

Built to Last

Heavy duty steel body and induction-hardened heads provide years of useful service.

Easier Handling

Each Universal Tool has a sturdy handle for easier handling of the tool body.

Simplifies Installations

Simplifies Standard, Grit Guard®, and Guardian® ring installation for quicker turnarounds.

Universal Axle Tools

Universal Axle Tools by Guardian® Seal Number

| Guardian® Seal | Inner Bearing Cone Number | Inner Bearing Cone ID or Spindle OD | Universal Axle Tool Head |
|----------------|---------------------------|-------------------------------------|--------------------------|
| 307-0713 1 | 663 | 3.250 | 555-5100 |
| 307-0723 1 | HM518445 | 3.500 | 555-5023 |
| 307-0743 1 | HM218248 | 3.542 | 555-5039 |
| 307-0744 | 665A | 3.375 | 555-5069 |
| 308-0836 1 | 39581 | 2.250 | 555-5062 |
| | HM212044,557A | 2.375 | 555-5061 |
| | HM212049,-X | 2.625 | 555-5098 |
| | HM212047 | 2.500 | 555-5066 |
| 308-0853 | 641/HM212049 | 2.625 | 555-5060 |
| | H715345 | 2.812 | 555-5070 |
| 308-0855 | 641 | 2.625 | 555-5060 |
| 308-0856 | H715345 | 2.812 | 555-5070 |
| 308-0863 | 39581 | 2.250 | 555-5062 |
| | 45284 | 2.000 | 555-5064 |
| 308-0864 1 | 6461A | 3.000 | 555-5007 |
| 308-0866 | JM207049 | 2.165 | 555-5088 |
| | JM205149 | 1.968 | 555-5089 |
| 308-0870 | JF7049A | 2.756 | 555-5297 |
| 309-0903 1 | 580/582 | 3.250 | 555-5072 |
| 309-0904 1 | 663/HM516449,-C | 3.250 | 555-5072 |
| | HM516449A | 3.250 | 555-5073 |
| 309-0912 | 47685/47686 | 3.250 | 555-5031 |
| | 47678/5760 | 3.000 | 555-5074 |

| Guardian® Seal | Inner Bearing Cone Number | Inner Bearing Cone ID or Spindle OD | Universal Axle Tool Head |
|----------------|---------------------------|-------------------------------------|--------------------------|
| 309-0915 | 47685/47686 | 3.250 | 555-5031 |
| | 47678 | 3.000 | 555-5074 |
| 309-0935 | 33287 | 2.875 | 555-5011 |
| | 33281 | 2.812 | 555-5002 |
| 309-0948 | 687/780 | 4.000 | 555-5004 |
| 309-0957 | 495AX | 3.000 | 555-5074 |
| | 33287 | 2.875 | 555-5011 |
| 309-0960 | 594A | 3.750 | 555-5076 |
| | 598A | 3.625 | 555-5071 |
| 309-0961 | 580/582/663A | 3.250 | 555-5072 |
| 309-0964 | 594/594A | 3.750 | 555-5076 |
| 309-0965 | 595 | 3.250 | 555-5072 |
| | 598 | 3.625 | 555-5071 |
| 309-0970 | 683XA/683 | 3.750 | 555-5076 |
| | 681A | 3.625 | 555-5071 |
| 309-0973 1 | 594/594A | 3.750 | 555-5076 |
| | 598/598A | 3.625 | 555-5071 |
| 381-0148 2 | H414245A | 2.688 | 555-5291 |
| 381-0150 2 | HM212047 | 2.500 | 555-5295 |
| 391-0138 2 | 32219 | 3.740 | 555-5292 |
| 391-0139 2 | 32216 | 3.150 | 555-5296 |
| 391-9066 2 | 594A | 3.750 | 555-5076 |

1 HP Design
2 SS4 Seal

Use Universal Tool Body 555-0001 with 555 Series Tool Heads.

Universal Axle Tools by Axle/Deflector Ring Number

| Axle Ring | Seal Set | Inner Bearing Cone Number | Inner Bearing Cone ID or Spindle OD | Universal Axle Tool Head |
|-----------|----------|---------------------------|-------------------------------------|--------------------------|
| 310-1007 | 392-9007 | 663, HM516449 | 3.250 | 555-5072 |
| | 372-7046 | 28995 | 2.469 | 555-5052 |
| 310-1008 | 382-8018 | 45284 | 2.000 | 555-5064 |
| | 382-8044 | 45284 | 2.000 | 555-5064 |
| | 382-8066 | JM207049 | 2.165 | 555-5088 |
| | 382-8066 | JM205149 | 1.968 | 555-5089 |
| 310-1009 | 382-8052 | 6386A | 2.625 | 555-5060 |
| 310-1012 | 392-9012 | 47686 | 3.250 | 555-5031 |
| | 392-9012 | 5760,47678 | 3.000 | 555-5074 |
| 310-1013 | 382-8001 | 6379 | 2.562 | 555-5014 |
| | 382-8001 | 6386, 6389 | 2.625 | 555-5060 |
| 310-1017 | None | 663 | 3.250 | 555-5100 |
| | 382-8017 | 39581 | 2.250 | 555-5062 |
| 310-1018 | 392-9018 | 495AX | 3.000 | 555-5074 |
| | 392-9057 | 495AX | 3.000 | 555-5074 |
| 310-1022 | 392-9057 | 33287 | 2.875 | 555-5011 |
| | 372-7022 | 593 | 3.500 | N/A |
| 310-1023 | 372-7024 | 749, 749S | 3.347 | 555-5024 |
| | None | HM518445 | 3.500 | 555-5023 |

| Axle Ring | Seal Set | Inner Bearing Cone Number | Inner Bearing Cone ID or Spindle OD | Universal Axle Tool Head |
|-----------|----------|---------------------------|-------------------------------------|--------------------------|
| 310-1026 | None | 595 | 3.250 | 555-5072 |
| | None | 598 | 3.625 | 555-5071 |
| 310-1027 | None | 663 | 3.250 | 555-5031 |
| 310-1028 | 382-8028 | 756A | 3.125 | 555-5067 |
| | 382-8045 | 756A | 3.125 | 555-5067 |
| 310-1032 | 382-8032 | HM212049 | 2.625 | N/A |
| 310-1034 | 382-8071 | HM212047 | 3.625 | 555-5066 |
| | 372-7006 | 567 | 2.875 | 555-5011 |
| 310-1036 | 382-8027 | 39581 | 2.250 | 555-5062 |
| | 382-8036 | 557A, HM212044 | 2.375 | 555-5061 |
| | | HM212047 | 2.500 | 555-5066 |
| | | HM212049,-X | 2.625 | 555-5098 |
| | 382-8063 | 39581 | 2.250 | 555-5062 |
| | | 45284 | 2.000 | 555-5064 |
| 310-1037 | 382-8064 | 6461A | 3.000 | 555-5007 |
| | None | 665A | 3.375 | 555-5069 |
| 310-1038 | 382-8039 | HM212049, 641 | 2.625 | N/A |
| 310-1041 | 382-8060 | 5760, 6461 | 3.000 | N/A |
| 310-1043 | 372-7015 | 759 | 3.500 | 555-5023 |

Use Universal Tool Body 555-0001 with 555 Series Tool Heads.

Universal Axle Tools

Universal Axle Tools by Axle/Deflector Ring Number

| Axle Ring | Seal Set | Inner Bearing Cone Number | Inner Bearing Cone ID or Spindle OD | Universal Axle Tool Head |
|-----------|----------|---------------------------|-------------------------------------|--------------------------|
| 310-1045 | None | 760 | 3.562 | 555-5079 |
| 310-1048 | None | HM218248 | 3.542 | 555-5039 |
| 310-1050 | 382-8010 | 39578, 4595 | 2.125 | N/A |
| 310-1051 | 382-8011 | 559, 3982 | 2.500 | N/A |
| | 382-8062 | 39585 | 2.500 | N/A |
| 310-1052 | 382-8009 | 45284, 45285 | 2.000 | 555-5036 |
| | 392-9032 | 580 | 3.250 | 555-5072 |
| 310-1053 | 392-9032 | 575 | 3.000 | 555-5074 |
| 310-1057 | 372-7003 | 663 | 3.250 | 555-5031 |
| 310-1061 | 382-8005 | 3778 | 1.875 | 555-5001 |
| 310-1062 | 392-9035 | 33281 | 2.812 | 555-5002 |
| | 392-9035 | 33287 | 2.875 | 555-5011 |
| 310-1063 | 392-9036 | 33281 | 2.812 | 555-5002 |
| 310-1064 | 372-7049 | JM511946 | 2.557 | 555-5055 |
| | 392-9038 | 3984 | 2.625 | 555-5097 |
| 310-1066 | 392-9034 | 6580 | 3.500 | 555-5023 |
| | 392-9034 | 6559 | 3.250 | 555-5072 |
| 310-1079 | 392-9081 | 598A | 3.625 | 555-5071 |
| 310-1088 | None | 663, HM516449 | 3.250 | 555-5072 |
| 310-1089 | 392-9053 | 782 | 4.125 | 555-5016 |
| 310-1093 | 382-8053 | 641, HM212049 | 2.625 | 555-5060 |
| | 382-8053 | H715345 | 2.812 | 555-5070 |
| | 382-8056 | H715345 | 2.812 | 555-5070 |
| | 382-8056 | 641 | 2.625 | 555-5060 |
| | None | 580, 582 | 3.250 | 555-5072 |
| | None | 594, 594A | 3.750 | 555-5076 |
| 310-1103 | 392-9062 | 760 | 3.562 | 555-5079 |
| 310-1104 | 392-9063 | 387AS, 7451929 | 2.250 | 555-5062 |
| | 392-9063 | 188931 | 2.265 | 555-5054 |
| 310-1107 | 392-9066 | 594A | 3.750 | 555-5076 |
| 310-1111 | None | 598A, 598 | 3.625 | 555-5071 |
| | None | 594, 594A | 3.750 | 555-5076 |
| | None | 683 | 3.750 | 555-5076 |
| | None | 681A | 3.625 | 555-5071 |
| 310-1117 | None | 495AX | 3.000 | 555-5074 |
| | None | 47686 | 3.250 | 555-5031 |
| 310-1130 | 372-7062 | 592A, 593 | 3.500 | 555-5023 |
| 310-1132 | 383-8139 | 663/641 | | |
| | 383-8239 | HM212011/ HM212049 | 2.625 | N/A |
| 310-1233 | 392-9111 | 594/593X | 3.750 | 555-5076 |
| 315-1501 | 392-9099 | 47685, 47686 | 3.250 | 555-5031 |
| | 392-9099 | 47678 | 3.000 | 555-5074 |
| | 392-9087 | 681A | 3.625 | 555-5071 |
| 315-1502 | 392-9087 | 683 | 3.750 | 555-5076 |
| | 392-9097 | 594A, 598A | 3.625 | 555-5071 |
| 315-1503 | 372-7091 | 749, 749S | 3.347 | 555-5024 |
| | 372-7099 | HM518445 | 3.500 | 555-5023 |
| 315-1504 | 372-7097 | HM218248 | 3.542 | 555-5039 |
| 315-1506 | 372-7096 | 787 | 4.125 | 555-5016 |
| 315-1507 | 372-7098 | 663 | 3.250 | 555-5100 |

| Axle Ring | Seal Set | Inner Bearing Cone Number | Inner Bearing Cone ID or Spindle OD | Universal Axle Tool Head |
|-----------|----------|---------------------------|-------------------------------------|--------------------------|
| 315-1508 | 392-9092 | 598 | 3.625 | 555-5071 |
| | 392-9096 | 598 | 3.625 | 555-5071 |
| | 392-9096 | 595 | 3.250 | 555-5072 |
| 315-1509 | 392-9095 | 582, 663A | 3.250 | 555-5072 |
| 315-1510 | 372-7095 | 665A | 3.375 | 555-5069 |
| 315-1511 | 392-9094 | 580, 582 | 3.250 | 555-5072 |
| 315-1515 | 392-9112 | 663, HM516449 | 3.250 | 555-5072 |
| | | 687, 780 | 4.000 | 555-5004 |
| 315-1516 | 392-9089 | 594, 594A | 3.750 | 555-5076 |
| 315-1517 | 392-9088 | 594, 594A | 3.750 | 555-5076 |
| 315-1519 | 392-9130 | HM516449A | 3.250 | 555-5073 |
| 315-1525 | 392-9131 | 598A | 3.625 | 555-5071 |
| | 392-9131 | 594A | 3.750 | 555-5076 |
| 315-1530 | 392-9132 | 594A | 3.750 | 555-5076 |
| | 392-9132 | 598A | 3.625 | 555-5071 |



Use Universal Tool Body 555-0001 with 555 Series Tool Heads.

Universal Axle Tools

Universal Axle Tools by Tool Head Number

| Universal Axle Tool Head No. | Inner Cone | Guardian® Seal Axle Ring or Deflector Ring | Universal Axle Tool Head No. | Inner Cone | Guardian® Seal Axle Ring or Deflector Ring | Universal Axle Tool Head No. | Inner Cone | Guardian® Seal Axle Ring or Deflector Ring | |
|------------------------------|--|--|------------------------------|---------------------------|--|--|--|--|--|
| 555-5001 | 3778 | 310-1061 | 555-5061 | HM212044 557A | 308-0836 310-1036 | 555-5074 | 47678 5760 495AX 42688 575 | 309-0912 309-0957 310-1012 310-1018 310-1053 310-1117 315-1501 | |
| 555-5002 | 33281 | 309-0935 310-1062 | 555-5062 | 39581 387AS 7451929 | 308-0836 308-0863 310-1017 310-1036 310-1068 310-1104 | | 555-5076 | 594A 594 693 683XA 683 598A | 309-0960 309-0964 309-0970 309-0973 310-1093 310-1107 310-1111 310-1233 315-1502 315-1517 315-1525 315-1530 391-9066 |
| 555-5004 | 687 780 | 309-0948 315-1516 310-1067 | | 555-5064 | 45284 | | | 308-0863 310-1008 310-1036 | 555-5079 |
| 555-5007 | 6461A | 308-0864 310-1026 ¹ 310-1037 | 555-5066 | HM212047 | 308-0836 310-1034 310-1036 | 555-5081 | | | 310-1007 |
| 555-5011 | 33287 567 | 309-0935 309-0957 310-1036 310-1062 | 555-5067 | 756A | 310-1028 | 555-5088 | JM207049 | 308-0866 310-1008 | |
| 555-5014 | 6379 | 310-1013 | 555-5069 | 665A 758 | 307-0744 310-1037 310-1095 315-1510 | 555-5089 | JM205149 | 308-0866 310-1008 | |
| 555-5016 | 782, 787 | 310-1089 315-1506 | 555-5070 | H715345 | 308-0853 308-0856 310-1093 | 555-5098 | HM212049,-X | 308-0836 310-1036 | |
| 555-5023 | HM518445 759 6580 592A 593 | 307-0723 310-1023 310-1043 310-1066 310-1130 315-1503 | 555-5071 | 598 598A 681A | 309-0960 309-0965 309-0970 309-0973 310-1026 310-1028 310-1079 310-1111 315-1502 315-1508 315-1525 315-1530 | 555-5100 | 663, 6386 | 307-0713 310-1013 310-1028 315-1507 | |
| 555-5024 | 749 749S | 310-1005 315-1503 | | 555-5072 | H715345 580 582 663-A, HM516449,-A 595 598 6559 | 308-0856 309-0903 309-0904 309-0961 309-0965 310-1007 310-1026 310-1028 310-1053 310-1066 310-1088 310-1093 315-1508 315-1509 315-1511 315-1515 | 555-5291 | H414245A | 381-0148 |
| 555-5031 | 47685 47686 663 | 309-0912 309-0915 310-1012 310-1027 310-1057 310-1091 310-1117 315-1501 | | | 555-5073 | HM516449A | 315-1519 | 555-5292 | 32219 |
| 555-5036 | 45284, 45285 | 310-1052 | | | | | 555-5295 | HM212047 | 381-0150 |
| 555-5039 | HM218248 | 307-0743 310-1048 315-1504 | | | | 555-5296 | 32216 | 391-0139 | |
| 555-5052 | 28995 | 310-1008 | | | | 555-5297 | JF7049A | 308-0870 | |
| 555-5054 | 188931 | 310-1068 310-1104 | | | | | | | |
| 555-5055 | JM511946 | 310-1064 | | | | | | | |
| 555-5060 | 641 HM212049 6386A 6386 6389 | 308-0853 308-0855 310-1009 310-1013 310-1093 | | | | | | | |

¹ This tool is used with the 310-1026 ring ONLY on Rogers Bros. Spindle R3329. For other options with the 310-1026 ring see 555-5071 and 555-5072.

Fleet Hub Tools

Fleet Hub Tools by Standard/Grit Guard® Oil Seal Number

| Oil Seal | Hub Tool | Hub-Seal Sets |
|----------|----------|--|
| 320-2001 | 551-5398 | 392-9001, 392-9062 |
| 320-2007 | 551-5326 | 372-7045 |
| 320-2009 | 551-5356 | 392-9019, 392-9081 |
| 320-2012 | 551-5405 | 392-9012 |
| 320-2017 | 551-5352 | 382-8017 |
| 320-2018 | 551-5351 | 372-7046, 382-8018 |
| 320-2021 | 551-5385 | 392-9021 |
| 320-2022 | 551-5381 | 382-8010 |
| 320-2023 | 551-5401 | 372-7020, 372-7022, 372-7062, 372-7099, 382-8060 |
| 320-2028 | 551-5385 | 382-8028, 392-9043 |
| 320-2029 | 551-5386 | 372-7018, 382-8029, 392-9018 |
| 320-2031 | 551-5388 | 372-7055, 372-7056, 382-8011, 382-8025 |
| 320-2032 | 551-5388 | 372-7009, 382-8032 |
| 320-2034 | 551-5387 | 382-8034 |
| 320-2036 | 551-5346 | 382-8036 |
| 320-2039 | 551-5395 | 382-8023, 382-8039 |
| 320-2041 | 551-5398 | 372-7004, 372-7015, 372-7017, 382-8045 |
| 320-2046 | 551-5388 | 372-7005, 372-7006 |
| 320-2050 | 551-5347 | 382-8009 |
| 320-2051 | 551-5388 | 372-7008 |
| 320-2056 | 551-5302 | 382-8005 |
| 320-2057 | 551-5353 | 392-9035, 392-9036 |
| 320-2058 | 551-5303 | 392-9033 |
| 320-2059 | 551-5317 | See 392-9053 Remarks |
| 320-2061 | 551-5356 | 392-9034 |
| 320-2072 | 551-5308 | 372-7048, 392-9038 |
| 320-2077 | 551-5362 | 392-9063 |
| 320-2086 | 551-5311 | 382-8001 |
| 320-2091 | 551-5312 | See 392-9045 Remarks |
| 320-2096 | 551-5390 | 392-9007 |

| Oil Seal | Hub Tool | Hub-Seal Sets |
|----------|----------|--|
| 320-2097 | 551-5400 | 392-9089 |
| 320-2099 | 551-5317 | 392-9053 |
| 320-2102 | 551-5318 | 392-9099 |
| 320-2104 | 551-5383 | 392-9057 |
| 320-2105 | 551-5351 | 382-8044 |
| 320-2106 | 551-5320 | 392-9131 |
| 320-2109 | 551-5313 | 372-7003, 372-7098, 392-9032 |
| 320-2110 | 551-5412 | 372-7097 |
| 320-2111 | 551-5323 | 372-7096 |
| 320-2113 | 551-5412 | 392-9088 |
| 320-2114 | 551-5412 | 392-9096 |
| 320-2115 | 551-5356 | 392-9020, 392-9066, 392-9132 |
| 320-2116 | 551-5317 | 382-8047 |
| 320-2117 | 551-5325 | 392-9095 |
| 320-2118 | 551-5321 | 372-7095 |
| 320-2119 | 551-5353 | 382-8027 |
| 320-2125 | 551-5388 | 382-8062 |
| 320-2129 | 551-5393 | 392-9094 |
| 320-2131 | 551-5363 | 392-9092 |
| 320-2133 | 551-5353 | 382-8063 |
| 320-2136 | 551-5381 | 372-7049 |
| 320-2137 | 551-5327 | 382-8064 |
| 320-2162 | 551-5333 | 392-9087 |
| 320-2164 | 551-5366 | 382-8066 |
| 320-2166 | 551-5340 | 382-8069 |
| 320-2173 | 551-5401 | 372-7024, 372-7026, 372-7027, 372-7028, 372-7091 |
| 320-2181 | 551-5349 | 382-8053, 382-8052 |
| 320-2199 | 551-5344 | 382-8056 |
| 320-2213 | 551-5364 | 392-9112, 392-9130 |
| 320-2216 | 551-5403 | 382-8071 |
| 320-2233 | 551-5404 | 392-9111 |

Note: In order for STEMCO warranty to apply, the product must be correctly installed with an installation tool manufactured by STEMCO.

Fleet Hub Tools by Voyager® & Discover® Number

| Voyager®/Discover® | Hub Tool |
|--------------------|----------|
| 373-0113 | 551-5313 |
| 373-0213 | |
| 373-0123 | 551-5401 |
| 373-0223 | |
| 373-0143 | 551-5412 |
| 373-0243 | |
| 373-0144 | 551-5339 |
| 373-0191 | |
| 383-0101 | 551-5420 |
| 383-0136 | |
| 383-0236 | 551-5346 |
| 383-0139 | |
| 383-0239 | 551-5413 |
| 383-0153 | |
| 383-0156 | 551-5419 |
| 383-0164 | |
| 383-0264 | 551-5344 |
| 383-0166 | |
| 383-0166 | 551-5327 |
| 383-0171 | |
| 383-0175 | 551-5423 |
| | |
| | 551-5403 |
| | |
| | 551-5417 |
| | |

| Voyager®/Discover® | Hub Tool |
|--------------------|----------|
| 383-0176 | 551-5418 |
| 393-0103 | 551-5415 |
| 393-0203 | |
| 393-0104 | 551-5414 |
| 393-0204 | |
| 393-0112 | 551-5416 |
| 393-0212 | |
| 393-0115 | 551-5424 |
| 393-0134 | |
| 393-0148 | 551-5421 |
| 393-0173 | |
| 393-0273 | 551-5400 |
| 320-2058 | |
| 320-2059 | 551-5320 |
| 320-2061 | |
| 320-2072 | 551-5303 |
| 320-2077 | |
| 320-2086 | 551-5317 |
| 320-2091 | |
| 320-2096 | 551-5356 |
| | |
| | 551-5308 |
| | |
| | 551-5362 |
| | |
| | 551-5311 |
| | |
| | 551-5312 |
| | |
| | 551-5390 |
| | |

Use Universal Tool Body 555-0001 with 555 Series Tool Heads.

Fleet Hub Tools by Tool Head Number

| Tool No. | Seal No. | Tool No. | Seal No. | Tool No. | Seal No. |
|----------|----------|----------|----------|----------|----------|
| 551-5302 | 320-2056 | 551-5351 | 320-2018 | 551-5400 | 320-2097 |
| 551-5303 | 320-2058 | | 320-2105 | | 393-0148 |
| 551-5308 | 320-2072 | 551-5353 | 320-2057 | 551-5401 | 320-2023 |
| 551-5311 | 320-2086 | | 320-2119 | | 320-2173 |
| 551-5312 | 320-2091 | | 320-2133 | | 373-0123 |
| 551-5313 | 373-0113 | 320-2009 | 373-0191 | | |
| | 373-0213 | 320-2061 | 373-0223 | | |
| | 320-2109 | 320-2115 | 320-2216 | | |
| 551-5317 | 320-2059 | 551-5362 | 320-2077 | 551-5403 | 383-0171 |
| | 320-2099 | 551-5363 | 320-2131 | 551-5404 | 320-2233 |
| | 320-2116 | 551-5364 | 320-2213 | 551-5405 | 320-2012 |
| 551-5318 | 320-2102 | | 393-0104 | 551-5412 | 320-2110 |
| 551-5320 | 320-2106 | | 393-0204 | | 320-2113 |
| | 393-0173 | 551-5366 | 320-2164 | | 320-2114 |
| | 393-0273 | 551-5381 | 320-2022 | | 373-0143 |
| 551-5321 | 320-2118 | | 320-2136 | 373-0243 | |
| 551-5323 | 320-2111 | 551-5383 | 320-2104 | 551-5413 | 383-0139 |
| 551-5325 | 320-2117 | 551-5385 | 320-2028 | 551-5414 | 383-0239 |
| 551-5327 | 320-2137 | 551-5386 | 320-2029 | | 393-0104 |
| | 383-0164 | 551-5387 | 320-2034 | 393-0204 | |
| | 383-0264 | 551-5388 | 320-2031 | 551-5415 | 393-0103 |
| 551-5333 | 320-2162 | | 320-2032 | | 393-0203 |
| 551-5339 | 373-0144 | | 320-2046 | | 393-0112 |
| 551-5344 | 320-2199 | | 320-2125 | | 393-0212 |
| | 383-0156 | 551-5390 | 320-2096 | 551-5417 | 383-0175 |
| 551-5346 | 320-2036 | 551-5393 | 320-2129 | 551-5418 | 383-0176 |
| | 383-0136 | | 383-0103 | 551-5419 | 383-0153 |
| | 383-0236 | | 383-0203 | 551-5420 | 383-0101 |
| 551-5347 | 320-2050 | 551-5395 | 320-2039 | 551-5421 | 393-0134 |
| 551-5349 | 320-2181 | 551-5398 | 320-2001 | 551-5423 | 383-0166 |
| | | | 320-2041 | 551-5424 | 393-0115 |

Note: In order for STEMCO warranty to apply, the product must be correctly installed with an installation tool manufactured by STEMCO.

Use Universal Tool Body 555-0001 with 555 Series Tool Heads.

Bearing Guides By Cone Number

| Tool No. | Seal No. | Tool No. | Seal No. | Tool No. | Seal No. | Tool No. | Seal No. |
|----------|----------|----------|----------|----------|----------|----------------|----------|
| 387AS | 570-0017 | 663 | 570-0023 | 5584 | 570-0019 | 47685 | 570-0023 |
| 495AX | 570-0022 | 663A | 570-0023 | 5760 | 570-0022 | 47686 | 570-0023 |
| 555S | 570-0017 | 665 | 570-0024 | 6386 | 570-0020 | 188931 | 570-0017 |
| 557A | 570-0018 | 665A | 570-0024 | 6386A | 570-0020 | 7451929 | 570-0017 |
| 559 | 570-0019 | 681A | 570-0027 | 6389 | 570-0020 | H715345 | 570-0021 |
| 575 | 570-0022 | 683 | 570-0028 | 6461 | 570-0022 | HM212044 | 570-0018 |
| 580 | 570-0023 | 683XA | 570-0028 | 6461A | 570-0022 | HM212046 | 570-0019 |
| 582 | 570-0023 | 687 | 570-0032 | 6559 | 570-0023 | HM212047 | 570-0019 |
| 593 | 570-0025 | 748S | 570-0022 | 6580 | 570-0025 | HM212049 | 570-0020 |
| 594 | 570-0028 | 749A | 570-0023 | 33212 | 570-0031 | HM212049X | 570-0020 |
| 594A | 570-0028 | 758 | 570-0024 | 33281 | 570-0021 | HM218248 | 570-0026 |
| 595 | 570-0023 | 759 | 570-0025 | 39250 | 570-0019 | HM516449,-A,-C | 570-0023 |
| 598 | 570-0027 | 760 | 570-0026 | 39581 | 570-0017 | HM518445 | 570-0025 |
| 598A | 570-0027 | 843 | 570-0022 | 30585 | 570-0019 | JM205149A | 570-0033 |
| 623 | 570-0017 | 3982 | 570-0019 | 42687 | 570-0022 | JM207049A | 570-0036 |
| 639 | 570-0019 | 3984 | 570-0020 | 42688 | 570-0022 | | |
| 641 | 570-0020 | 3994 | 570-0020 | 47678 | 570-0022 | | |

High impact, accurate guides designed to align the STEMCO seal with the hub bore, thereby eliminating the cocked seal. To be used with the designated hub tool designed for the seal being installed.

Miscellaneous Tools

| Tool | Tool No. | Tool | Tool No. |
|----------------|----------|---------------------------|----------|
| Dial Indicator | 102-5003 | Grease Template Fill Tool | 359-4000 |

Heavy Duty Axle Tools

Heavy Duty Axle Tools By Guardian® Seal Number

| Guardian® Seal | Inner Cone | Outer Cone | Tool Number |
|--|------------|------------|-------------|
| 307-0713 | 663 | 560 | 552-5212 |
| | | HM212049 | 552-5359 |
| 307-0723 | HM518445 | HM518445 | 552-5239 |
| 307-0743 | HM218248 | HM212049 | 552-5236 |
| 307-0744 | 665A | HM212049 | 552-5233 |
| 308-0836 | HM212044 | 3782 | 552-5206 |
| | 557A | 3782 | 552-5206 |
| | HM212049-X | 3782 | 552-5288 |
| | HM212047 | 3782 | 552-5230 |
| 308-0853 | H715345 | 3979 | 552-5223 |
| 308-0856 | H715345 | 28682 | 552-5223 |
| | | 555S | 552-5223 |
| 308-0864 | 6461A | 555S | 552-5220 |
| | | 3979 | 552-5220 |
| 309-0903 | 580 | 567 | 552-5221 |
| | | 582 | 552-5221 |
| 309-0904 | 663 | 575 | 552-5226 |
| | | HM516449-C | 47679 |
| 309-0912 | 47685 | 39590 | 552-5359 |
| | | 47686 | 39590 |

| Guardian® Seal | Inner Cone | Outer Cone | Tool Number | |
|--|------------|------------|-------------|----------|
| 309-0915 | 47685 | 39590 | 552-5359 | |
| | | 47686 | 39590 | 552-5359 |
| 309-0960 | 598A | 580/582 | 552-5214 | |
| | | 594A | 580/582 | 552-5216 |
| 309-0961 | 580 | 42687 | 552-5221 | |
| | | 582 | 42687 | 552-5221 |
| | | 663A | 42687 | 552-5221 |
| 309-0964 | 594 | 580 | 552-5216 | |
| | | 594A | 580 | 552-5216 |
| 309-0965 | 598 | 575 | 552-5215 | |
| | | 758 | 552-5215 | |
| | | 665 | 552-5215 | |
| | | HM617049 | 552-5215 | |
| 309-0970 | 681A | 575/580 | 552-5214 | |
| | | 580 | 552-5216 | |
| | | 683AX | 552-5216 | |
| 309-0973 | 598A | 580 | 552-5214 | |
| | | 575 | 552-5215 | |
| | | 580 | 552-5216 | |
| | | 594A | 580 | 552-5216 |

Note: In order for STEMCO warranty to apply, the product must be correctly installed with an installation tool manufactured by STEMCO.

Note: If heavy duty tool is not listed for a specific ring/seal use the 555 series tool head for that application.

 HP Design

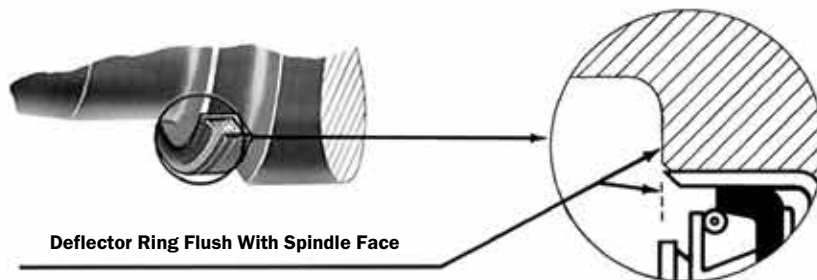

Heavy Duty Axle Tools

Heavy Duty Axle Tools By Axle/Deflector Ring Number

| Axle Ring/ Deflector Ring | Set Number | Inner Cone | Outer Cone | Tool Number |
|---------------------------------|----------------------|-------------------------------------|-----------------|--|
| 310-1007 | 392-9007 | 663, HM516449 | 575, 47679 | 552-5226 |
| 310-1012 | 392-9012 | 47686 | 39590 | 552-5359 |
| 310-1013 | None | 663 | HM212049 560 | 552-5359 |
| 310-1023 | None | HM518445 | HM518445 | 552-5239 |
| 310-1026 | None | 598 | 575 | 552-5215 |
| 310-1034 | 382-8071 382-8034 | HM212047 | 3779, 45282 | 552-5230 |
| 310-1036 | 372-7009 | 39250 | 4395 | 552-5231 |
| | 382-8025 | 557A | 3782 | 552-5206 |
| | 382-8036 | HM212044 HM212047 HM212049,-X | 3782 | 552-5206 552-5230 552-5288 |
| 310-1037 | None | 665A | HM212049 | 552-5233 |
| | 382-8064 | 6461A | 555S, 3979 | 552-5220 |
| 310-1043 | 372-7015 | 759 | 740 | 552-5237  |
| 310-1048 | None | HM218248 | HM212049 | 552-5236 |
| 310-1053 | 392-9032 | 580 | 567 | 552-5221 |
| 310-1057 | 372-7003 | 663 | HM212049 | 552-5359 |
| 310-1061 | 382-8005 | 3778 | 25877 | 552-5242 |
| | | | 2790 | 552-5243 |
| 310-1064 | 372-7048 | 3984 | 462 | 552-5247 |
| | 372-7049 | JM511946 | JM205149 | 552-5273 |
| | 392-9038 | 3984 | 462 | 552-5247 |
| 310-1088 | None | 663, HM516449 | 575, 47679 | 552-5226 |
| 310-1091 | None | 47685, 47686 | 39590 | 552-5359 |
| 310-1093 | 382-8053 | H715345 | 3979, 28682 | 552-5223 |
| | 382-8056 | H715345 | 28682, 555S | 552-5223 |
| | None | 580, 582 | 567 | 552-5221 |
| | None | 594 | 580 | 552-5216 |

| Axle Ring/ Deflector Ring | Set Number | Inner Cone | Outer Cone | Tool Number |
|---------------------------------|-------------------|---------------------|----------------------|--|
| 310-1111 | None | 598A | 582 | 552-5214 |
| | None | 681A | 580 | 552-5214 |
| | | 683 | 580 | 552-5216 |
| | None | 598A | 580 | 552-5214 |
| | | 598 | 575 | 552-5215 |
| | 594, 594A | 560, 580 | 552-5216 | |
| 310-1117 | 392-9045 | 47686 | 39590 | 552-5359 |
| 310-1130 | 372-7062 | 593 | 65390 HH506348 | 552-5239 |
| 310-1233 | 392-9111 | 593X/594 | 593X/594 | 552-5216 |
| 315-1501 | 392-9099 | 47685, 47686 | 39590 | 552-5359 |
| 315-1502 | 392-9087 | 681A | 580 | 552-5214 |
| | | 683 | 580 | 552-5216 |
| | | 681A | 575 | 552-5215 |
| | 392-9132 | 598A | 582 | 552-5214 |
| 392-9131 | 598 | 575 | 552-5215 | |
| | 594, 594A 598A | 580 | 552-5216 552-5214 | |
| 315-1503 | 372-7099 | HM518445 | HM518445 | 552-5239 |
| 315-1504 | 372-7097 | HM218248 | HM212049 | 552-5236 |
| 315-1506 | 372-7096 | 787 | 6580 | 552-5268  |
| 315-1507 | 372-7098 | 663 | HM212049 | 552-5359 |
| 315-1508 | 392-9096 | 598 | 575 | 552-5215 |
| 315-1509 | 392-9095 | 580, 582, 663A | 42687 | 552-5221 |
| 315-1510 | 372-7095 | 665A | HM212049 | 552-5233 |
| 315-1511 | 392-9094 | 580, 582 | 567 | 552-5221 |
| 315-1515 | 392-9112 | 663, HM516449,-C | 575, 47679 | 552-5226 |
| 315-1516 | 392-9089 | 780 | 776, 864 | 552-5271 |
| 315-1517 | 392-9088 | 594 | 580 | 552-5216 |
| 315-1525 | 392-9131 | 598 | 575 | 552-5215 |
| | | 594, 594A | 580 | 552-5216 |
| | | 598A | 580 | 552-5214 |

Note: If heavy duty tool is not listed for a specific ring/seal use the 555 series tool head for that application.

 Discontinued

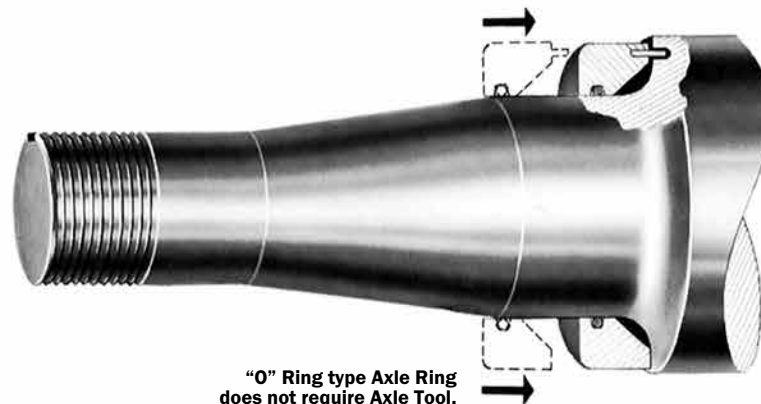

Heavy Duty Axle Tools

Heavy Duty Axle Tools By Tool Number

| Tool Number | Inner Cone | Outer Cone | Deflector Ring | Tool Number | Inner Cone | Outer Cone | Deflector Ring |
|-------------|------------------------------|--|--|-------------|-------------------------|----------------------------|--|
| 552-5214 | 598A, 681A | 580, 582, 575 | 309-0970 309-0973 315-1502 315-1525 315-1530 | 552-5223 | H715345 | 3979, 28682 | 308-0853 308-0855 308-0856 309-0903 310-1093 |
| 552-5215 | 598, 598A, 681A | 575 | 309-0965 309-0973 310-1026 315-1502 315-1508 315-1525 315-1530 | 552-5226 | 663, HM516449,-C | 575, 47679 | 309-0904 310-1007 315-1515 |
| 552-5216 | 594A, 594, 683, -XA | HM516449, 580, 560, 582, 575 | 309-0960 309-0964 309-0970 309-0973 310-1093 315-1502 315-1517 315-1525 | 552-5230 | HM212047 | 3779, 45282 | 310-1034 |
| 552-5220 | 6461A | 555S, 3979 | 308-0864 310-1037 | 552-5233 | 665A | HM212049, 641 | 307-0744 315-1510 |
| 552-5221 | 580, 582 | 567, 575 | 308-0856 309-0903 310-1053 315-1511 | 552-5236 | HM218248 | HM212049 | 307-0743 315-1504 |
| | | | | 552-5239 | HM518445 | HM518445 | 307-0723 310-1023 315-1503 |
| | | | | 552-5288 | HM212049, -X, X1 | 3782 | 308-0836 310-1036 |
| | | | | 552-5359 | 663, 47685, 47686 | 560, HM212049, 39590 | 307-0713 309-0912 309-0915 310-1012 310-1013 310-1057 310-1117 315-1501 315-1507 |

Note: In order for STEMCO warranty to apply, the product must be correctly installed with an installation tool manufactured by STEMCO.

Note: Hammer Assembly 552-5357, replaceable tips, 552-5358.